

ASEPTIQUIK® CONNECTOR

AseptiQuik® Connectors provide quick and easy sterile connections, even in non-sterile environments. AseptiQuik's "CLICK-PULL-TWIST" design enables users to transfer media easily with less risk of operator error. The connector's robust design provides reliable performance without the need for clamps, fixtures or tube welders. Biopharmaceutical manufacturers can make sterile connections with the quality and market availability they expect from the leader in single-use connection technology.

- Features**
- CLICK-PULL-TWIST Design
 - Membrane Pull Tabs
 - Robust Construction
 - Integrated Lock Ring
 - Colder Click
 - Market Availability

- Benefits**
- Intuitive three-step connection process reduces risk of operator error
 - Ensure simultaneous and secure removal of both membranes
 - Repeatable and reliable performance with no additional hardware required
 - Secures final connection preventing disassembly
 - Audible confirmation of completed assembly steps
 - Open access through multiple supply chain partners

Visit us at www.colder.com/aseptiquik or call 651-645-0091 for more information.

- AseptiQuik Specifications**
- Pressure:** Up to 60 psi, 4.1 bar
- Temperature:** 39°F to 104°F (4°C to 40°C)
- Typical Flow Rate:** C_v = 14.4 max
- Sterilization:**
Gamma: Up to 50kGy irradiation
Autoclave:
High Temp (HT) Version: Up to 266°F (130°C) for 30 minutes
- Termination Sizes:** 1/2" ID hose barb, 3/8" ID hose barbs and 3/4" sanitary
- Materials:**
Main Components: Polycarbonate (white), USP Class VI, ADCF
Lock Ring: Polycarbonate (blue), USP Class VI, ADCF
Pull Tabs: Polycarbonate (blue, standard version), USP Class VI, ADCF
 Polycarbonate (white, HT version), USP Class VI, ADCF
Caps: Polypropylene (clear), USP Class VI, ADCF
Seals: Silicone (clear), platinum-cured, USP Class VI, ADCF
Membrane: Polyethylene (standard version), USP Class VI, ADCF
 Hydrophobic polyethersulfone (HT version), USP Class VI

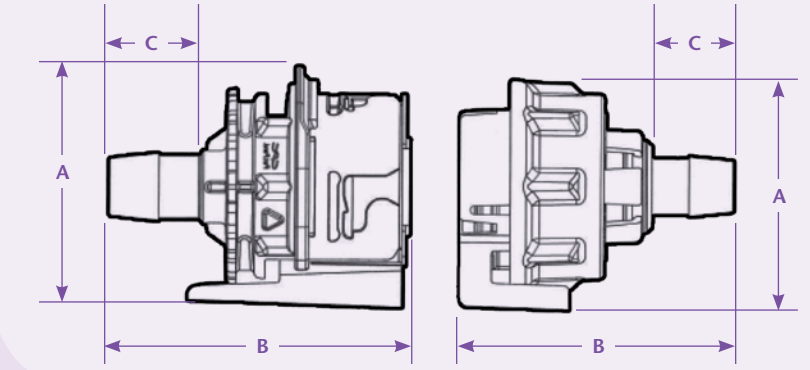

Product Dimensions

A = Height/Diameter
 B = Total Length
 C = Hose Barb Length

Coupling Bodies

POLYCARBONATE with Blue Pull Tabs

TERMINATION	PART NO.	A	B	C
1/2" HOSE BARB	AQC17008	2.36 (59.9)	2.95 (74.9)	0.89 (22.6)
3/8" HOSE BARB	AQC17006	2.36 (59.9)	2.74 (69.6)	0.65 (16.5)
3/4" SANITARY	AQC33012	2.36 (59.9)	2.73 (69.3)	0.70 (17.8)

Coupling Bodies - High Temperature

POLYCARBONATE with White Pull Tabs

TERMINATION	PART NO.	A	B	C
1/2" HOSE BARB	AQC17008HT	2.36 (59.9)	2.95 (74.9)	0.89 (22.6)
3/8" HOSE BARB	AQC17006HT	2.36 (59.9)	2.74 (69.6)	0.65 (16.5)
3/4" SANITARY	AQC33012HT	2.36 (59.9)	2.73 (69.3)	0.70 (17.8)

Coupling Inserts

POLYCARBONATE with Blue Pull Tabs

TERMINATION	PART NO.	A	B	C
1/2" HOSE BARB	AQC22008	2.50 (63.5)	2.99 (75.9)	0.89 (22.6)
3/8" HOSE BARB	AQC22006	2.50 (63.5)	2.90 (73.7)	0.65 (16.5)
3/4" SANITARY	AQC44012	2.50 (63.5)	2.80 (71.1)	0.70 (17.8)

Coupling Inserts - High Temperature

POLYCARBONATE with White Pull Tabs

TERMINATION	PART NO.	A	B	C
1/2" HOSE BARB	AQC22008HT	2.50 (63.5)	2.99 (75.9)	0.89 (22.6)
3/8" HOSE BARB	AQC22006HT	2.50 (63.5)	2.90 (73.7)	0.65 (16.5)
3/4" SANITARY	AQC44012HT	2.50 (63.5)	2.80 (71.1)	0.70 (17.8)

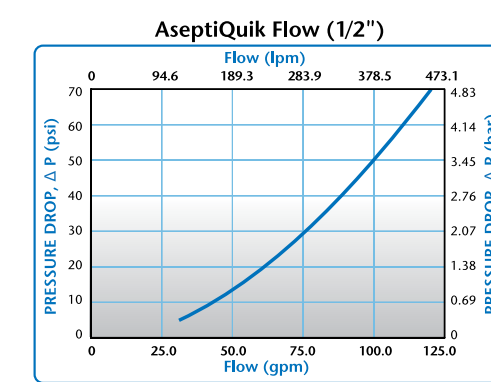

This graph is intended to give you a general idea of the performance of the product.

Pre-Assembly Cap Removal

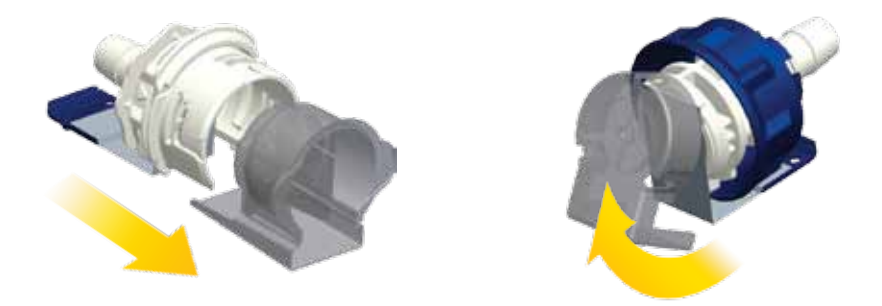

CLICK-PULL-TWIST Assembly Procedure

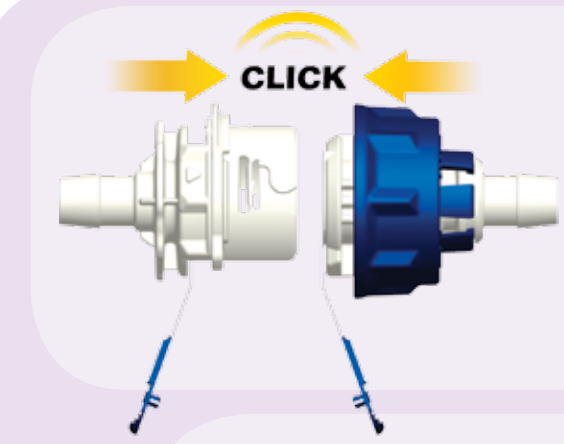

Align male and female couplings, push together until audible "Colder Click" confirmation. Slight rotation of lock ring may be required for proper alignment prior to connection.

Snap membrane pull tabs together and pull from connector.



Twist the blue lock ring clockwise until audible "Colder Click." Alignment of the lock ring rib with the body's arrow indicator confirms final connection.

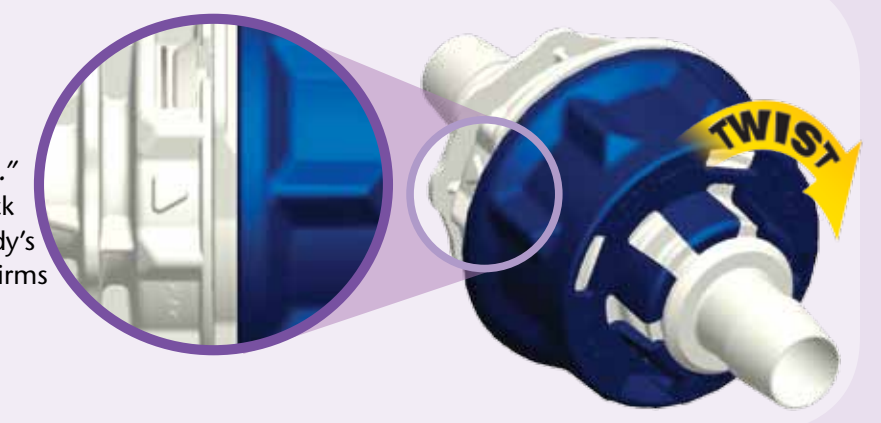

Connect with Colder Sterile Fluid Transfer

RELIABLE FLEX ASEPTIQUIK CONNECTOR

RELIABLE FLEX ASEPTIQUIK CONNECTOR

RELIABLE FLEX ASEPTIQUIK CONNECTOR

RELIABLE FLEX ASEPTIQUIK CONNECTOR

APPLICATION

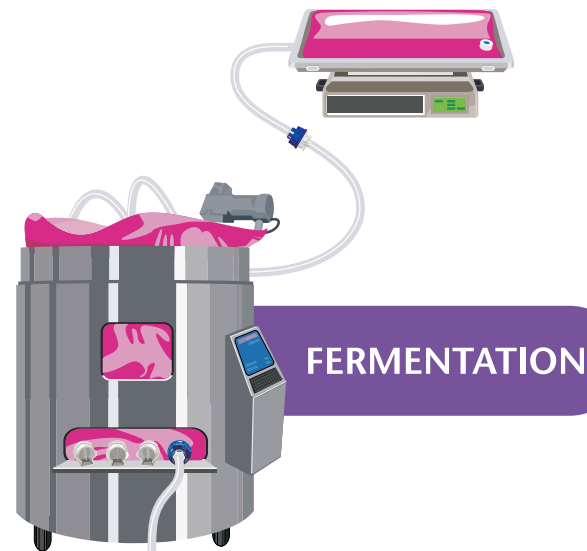

FERMENTATION

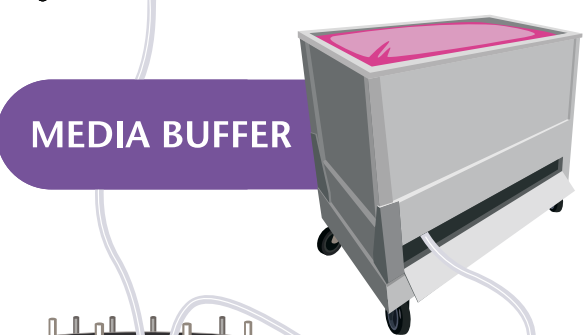

MEDIA BUFFER

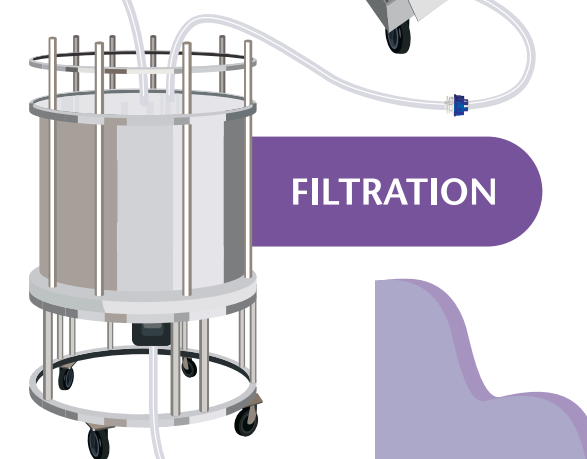

FILTRATION



FILLING

AseptiQuik® Connectors are ideal for a wide range of sterile fluid transfer applications which require a secure connection of two single-use assemblies. Pre-sterilized, gamma or autoclaved, AseptiQuik Connectors may be incorporated with filters, tubing and process containers to create systems that add flexibility throughout upstream or downstream processes. Whether in seed train applications, suite-to-suite transfer or filling operations, protect your valuable product with connection technology that provides sterile fluid transfer.

RELIABLE FLEXIBLE COMPATIBLE STERILE

COLDER PRODUCTS COMPANY

Colder Products Company is the leader in the design and manufacture of single-use connection technology and connectors for the life sciences markets. Colder offers a wide variety of bioprocessing solutions including sterile connect, sterile disconnect, SIP connections and quick connects. Our innovative designs provide flexibility for biopharmaceutical manufacturers to easily combine multiple components, single-use or hybrid systems including process containers, tubing manifolds, transfer lines, bioreactors and other bioprocess equipment.

Robust and easy-to-use single-use connectors from Colder maintain flow path sterility and integrity while enabling biopharmaceutical manufacturers to improve production yields, decrease time-to-market and reduce costs. Colder is ISO 13485 certified and our products for bioprocessing applications are manufactured in an ISO Class 7 certified cleanroom.

For applications where reliability and sterility are a must, Connect with Colder.

Founded in St. Paul, Minn. in 1978, Colder offers more than 7,500 standard and custom products with offices in nine countries and distributor representation in North America, Europe, Asia, South America and Australia. Colder is a Dover company.



Colder Products Company
1001 Westgate Drive
St. Paul, Minnesota 55114
U.S.A.

Phone: 651-645-0091
Fax: 651-645-5404
Toll Free: 800-444-2474
info@colder.com
www.colder.com

Distributed BY:

Colder Products Company GmbH
Schmalweg 50
D-55252 Mainz-Kastel
Germany

Phone: +49-6134-2878-0
Fax: +49-6134-287828

cpcgmbh@colder.com
www.colder.com

Colder Products Company Limited
Flat B, 29/F, West Gate Tower,
7 Wing Hong Street, Cheung Sha Wan,
Hong Kong

Phone: 852-2987-5272
Fax: 852-2987-2509

asiapacific@colder.com
www.colder.com

Colder Patent Statement: Colder Products Company takes pride in its innovative quick disconnect coupling solutions, many of which have been awarded United States and International patents. Colder Products Company has a strong tradition of leadership in the quick disconnect market, and aggressively pursues and protects its proprietary information and intellectual property. In cases where it is practical and as a benefit to its customers, Colder Products Company has licensed its proprietary technology. Please contact Colder Products to discuss your unique needs.

CPC Warranty Statement: Colder Products Company warrants its products against defects in workmanship and materials a period of 12 months from the date of sale by Colder Products Company to its initial customer (regardless of any subsequent sale of the products). This warranty is void if the product is misused, altered, tampered with or is installed or used in a manner that is inconsistent with Colder Product Company's written recommendations, specifications and/or instructions, or fails to perform due to normal wear and tear. Colder Products Company does not warrant the suitability of the product for any particular application. Determining product application suitability is solely the customer's responsibility. Colder Products Company is not liable for special, indirect, incidental, consequential or other damages including, but not limited to, loss, damage, personal injury, or any other expense directly or indirectly arising from the use of or inability to use its products either separately or in combination with other products. ALL OTHER WARRANTIES EXPRESS OR IMPLIED, WHETHER ORAL, WRITTEN OR IN ANY OTHER FORM, INCLUDING BUT NOT LIMITED TO WARRANTIES OF MERCHANTABILITY OR FITNESS FOR A PARTICULAR PURPOSE, ARE EXPRESSLY EXCLUDED.

The sole and exclusive remedy under this warranty is limited, at the option of Colder Products Company, to replacement of the defective product or an account credit in the amount of the original selling price. All allegedly defective Colder Products Company products must be returned prepaid transportation to Colder Products Company, together with information describing the product's application and performance, unless otherwise authorized in writing by Colder Products Company.

WARNING: Due to the wide variety of possible fluid media and operating conditions, unintended consequences may result from the use of this product, all of which are beyond the control of Colder. It is the user's responsibility to carefully determine and test for compatibility for use with their application. All such risks shall be assumed by the buyer.

CAT2026 05/10 3M/RRD Printed in U.S.A.



AseptiQuik®

Sterile Connection as easy as
Click-Pull-Twist



RELIABLE FLEXIBLE COMPATIBLE STERILE